

Introduction

This installation guide provides instructions for installation, startup, and adjustment. To receive a copy of the instruction manual, contact your local S.G. Sales Office or Sales Representative or view a copy at www.FISHERregulators.com. For further information refer to:

Type 119 Instruction Manual, form 5204, D100261X012.

P.E.D. Categories

This product may be used as a safety accessory with pressure equipment in the following Pressure Equipment Directive 97/23/EC categories. It may also be used outside of the Pressure Equipment Directive using sound engineering practice (SEP) per table below.

PRODUCT SIZE	CATEGORIES	FLUID TYPE
DN 6 (1-inch)	SEP	1

Specifications

Maximum Inlet Pressure⁽¹⁾

10.3 bar (150 psig)

Spring Ranges

0.2 to 1.0 bar (3 to 5 psig)
0.3 to 1.4 bar (5 to 20 psig)
0.3 to 2.4 bar (5 to 35 psig)
2.1 to 4.1 bar (30 to 60 psig)

Maximum Control Pressure to Diaphragm

10.3 bar (150 psig)

Maximum Pressure Drop⁽¹⁾

10.3 bar (150 psig) for all port diameters

Proof Test Pressure

All Pressure Retaining Components have been proof tested per Directive 97/23/EC - Annex 1, Section 7.4

Temperature Capabilities⁽¹⁾

Nitrile Elastomers: -29 to 77°C (-20 to 170°F)
Fluoroelastomers: -18 to 121°C (0 to 250°F)
Note: Not for use with hot water or ammonia.

Installation



WARNING

Only qualified personnel should install or service a regulator. Regulators should be installed, operated, and maintained in accordance with international and applicable codes and regulations, and S.G. instructions.

If the regulator vents fluid or a leak develops in the system, it indicates that service is required. Failure to take the regulator out of service immediately may create a hazardous condition.

Personal injury, equipment damage, or leakage due to escaping fluid or bursting of pressure-containing parts may result if this regulator is over-pressured or is installed where service conditions could exceed the limits given in the Specifications section, or where conditions exceed any ratings of the adjacent piping or piping connections.

To avoid such injury or damage, provide pressure-relieving or pressure-limiting devices (as required by the appropriate code, regulation, or standard) to prevent service conditions from exceeding limits.

Additionally, physical damage to the regulator could result in personal injury and property damage due to escaping fluid. To avoid such injury and damage, install the regulator in a safe location.

Clean out all pipelines before installation of the regulator and check to be sure the regulator has not been damaged or has collected foreign material during shipping. For NPT bodies, apply pipe compound to the male pipe threads. For flanged bodies, use suitable line gaskets and approved piping and bolting practices. Install the regulator in any position desired, unless otherwise specified, but be sure flow through the body is in the direction indicated by the arrow on the body.

Note

It is important that the regulator be installed so that the vent hole in the spring case is unobstructed at all times. For outdoor installations, the regulator should be located away from vehicular traffic and positioned so that water, ice, and other foreign materials cannot enter the spring case through the vent. Avoid placing the regulator beneath eaves or downspouts, and be sure it is above the probable snow level.

Overpressure Protection

The recommended pressure limitations are stamped on the regulator nameplate. Some type of overpressure protection is needed if the actual inlet pressure exceeds the maximum operating outlet pressure rating. Overpressure protection should also be provided if the regulator inlet pressure is greater than the safe working pressure of the downstream equipment.

Regulator operation below the maximum pressure limitations does not preclude the possibility of damage from external sources or debris in the line. The regulator should be inspected for damage after any overpressure condition.

Startup

The regulator is factory set at approximately the midpoint of the spring range or the pressure requested, so an initial adjustment may be required to give the desired results. With proper installation completed and relief valves properly adjusted, slowly open the upstream and downstream shutoff valves.

Type 119

Adjustment

To change the outlet pressure, remove the closing cap or loosen the locknut and turn the adjusting screw clockwise to increase outlet pressure or counterclockwise to decrease pressure. Monitor the outlet pressure with a test gauge during the adjustment. Replace the closing cap or tighten the locknut to maintain the desired setting.

Taking Out of Service (Shutdown)



WARNING

To avoid personal injury resulting from sudden release of pressure, isolate the regulator from all pressure before attempting disassembly.

Parts List

Key Description

1	Regulator Body
2	Spring Case
3	Orifice
4	Disk Holder Assembly
5	Diaphragm/Stem Assembly
6	Hair Pin Clip
7	Bushing Spacer
8	O-Ring
9	Bonnet
10	Internal Retaining Ring
11	Bonnet O-Ring
12	Adjusting Screw
13	Locknut
14	Cap Screw
16	Actuator Spring
17	Upper Spring Seat
19	Stem Wiper
20	Nameplate

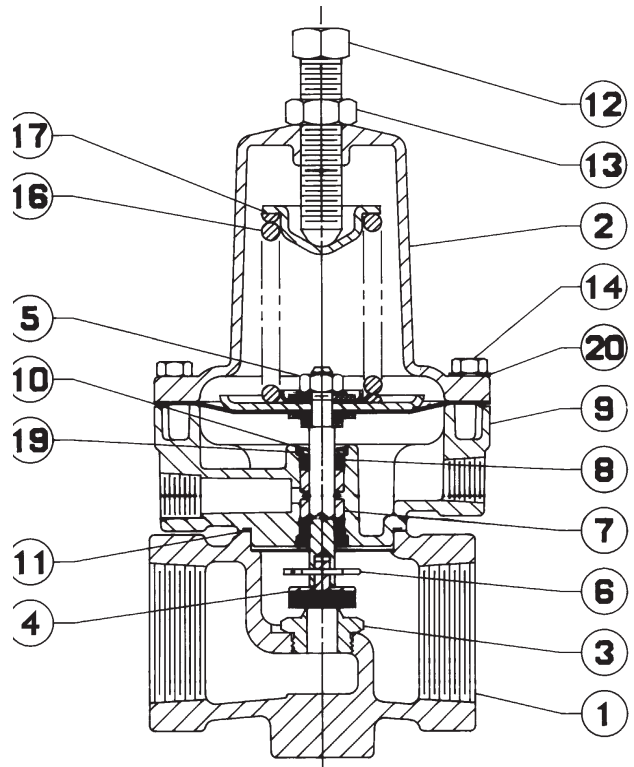

37A8078-C

Figure 1. Type 119 Control Valve