



SANAYE GAZ IRAN CO.



TARESTAN INDUSTRIAL SYSTEMS CO

# Pressure Regulator 12P

- Up to 40 bar inlet pressure
- Up to DN 100
- Approved by German DVGW
- Conform with 97/23EC (PED)
- Easy maintenance
- Wide range of flow

## Options

- Optical flow indicator
- Relief regulator
- Internal silencer
- SSV position indicator
- SSV with manual release
- SSV with electrical release by solenoid valve



Pressure Regulator 12P

## Description

The regulator 12P is designed for use in transmission and distribution networks, as well as commercial and industrial supplies.

The pilot Series RP and feeder Series RV ensure constant outlet pressure when the flow and / or the upstream pressure varies.

The regulator 12P is a pilot-operated gas pressure regulator available with or without an integrated safety shut-off device.

## Technical Data

Pressure rate	PN 16, PN 40, ANSI 150
Acceptable gases	Natural gas, propane, butane, air, nitrogen and all non-corrosive gases
Inlet pressure range (pe)	up to 40 bar
Outlet pressure range (pa)	10 mbar to 38 bar
Minimum pressure difference	0.5 - 1.5 bar
Flow rate	see table
Accuracy class / closing pressure group	up to AC 1 / up to SG 5
Closing pressure range	SZ 10 to SZ 2,5
Ambient temperature	-30°C to +60°C
Safety device	AG 1 to AG 30

## Connection

Sizes	DN 25, DN 50, DN 80 & DN 100
Flanges	PN 16, PN 40, ANSI 150
Dimension	see table

## Materials

Body regulator	EN-GJS-400-15 (GGG 40)
Actuator regulator	EN-GJS-400-15 (GGG 40)
Body Feeder / Pilot	Aluminium (AL Mg Si F28)
Actuator SSV	Steel, zinc coated, aluminium, brass
Internal parts	Steel, zinc coated, stainless steel, brass
Body Fine strainer	Steel, zinc coated
Body Needle valve	Aluminium (AL Mg Si F28)
Diaphragm / Valve seat	NBR rubber, fabric-reinforced / PUR / NBR
Seals	NBR rubber, viton
Filter cartridge	Paper filter

## Accuracy class (AC), Closing Group (SG) and Closing Range Group (SZ)

10 - 20 mbar	AC 20 / SG 50
> 20 - 50 mbar	AC 10 / SG 30
> 50 - 200 mbar	AC 5 / SG 10
> 0.2 bar	AC 2.5 / SG 10
> 6.0 bar	AC 1 / SG 5
Closing range group	SZ 10 to SZ 2.5

## Pilot and feeder in combination with main valve 12P

Feeder	Pilot	Pe (bar)	Pa (bar)
RV - MD	RP ND	19.3	0.01 - 0.15
RV - MD	RP - ND with SRV Type 285 D	40.0	0.01 - 0.15
RV - MD	RP - MD	40.0	0.1 - 12.0
RV - HD	RP - HD	40.0	6.0 - 38.0

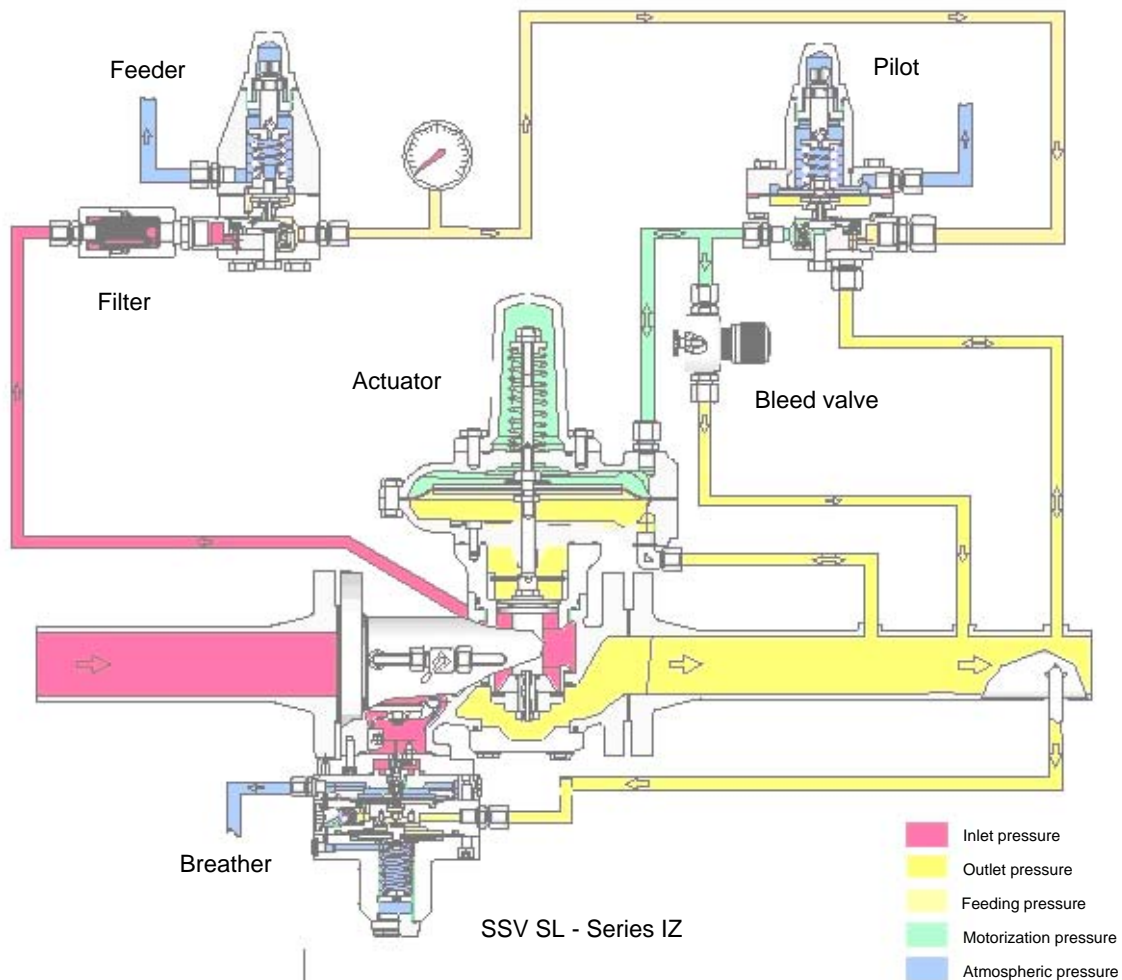

## Feeder Series RV

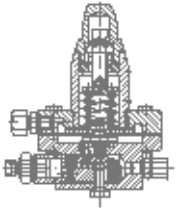

RV-MD

pe max. 40 bar

Spring range (bar)	Spring Code	Wire ø mm
0.4 –	3955-201-68	6
1 –	6955-201-69	7
4 –	13955-201-70	8.5

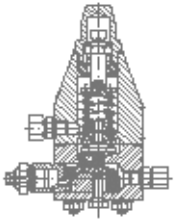

RV-HD

pe max. 40 bar

Spring Range (bar)	Spring Code	Wire ø mm
2 –	13955-201-68	6
11 –	30955-201-69	7
15 –	40955-201-70	8.5

## Pilot Series RP



RP-ND

pe max. 40 bar  
(in combination with SRV 285 D)

pe max. 19,3 bar

Spring Range (bar)	Spring Code	Wire ø mm
0.01 – 0.15	955-201-65	3.2



RP-MD

pe max. 40 bar

Spring Range (bar)	Spring Code	Wire ø mm
0.1 – 0.5	955-201-66	4
0.5 –	2955-201-68	6
1 –	6955-201-69	7
4 –	12955-201-70	8.5

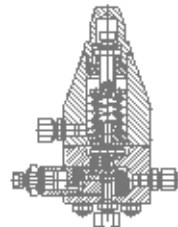

RP-HD

pe max. 40 bar

Spring Range (bar)	Spring Code	Wire ø mm
6 - 30	955-201-69	7
15 - 36	955-201-70	8.5

Remark:

Capacities are indicated for a regulator with an integrated safety shutoff valve.

When a noise abatement device is built into the regulator as well, the values mentioned in the tables - or calculated from the sizing equation - should be reduced by 10%.

## Capacity

Flow rate in m<sup>3</sup>/h Natural gas in standard condition (ρ<sub>n</sub> = 0,78 kg/m<sup>3</sup>)

KG-factor (Natural gas) 320		1550	3050	6000	
Inlet pressure	Outlet pressure	DN 25	DN 50	DN 80	DN 100
Pe (bar)	Pa (bar)				
0.8 < 0.02	0.05	270	1380	2700	5350
	0.1	265	1365	2670	5320
	0.2	260	1360	2650	5260
	0.3	250	1350	2530	5090
	0.5	240	1280	2400	4840
1 < 0.1	0.2	225	1160	2200	4020
	0.3	305	1540	2960	5970
	0.5	295	1510	2945	5880
1.5 < 0.3	0.5	270	1480	2890	5720
	0.5	210	1440	2720	5200
	0.5	400	1940	3800	7490
	0.8	390	1890	3720	7350
	1.0	360	1740	3410	6730
2 < 0.6	—	330	1650	3250	6000
	1.0	480	2330	4570	8980
	1.5	450	2190	4300	8490
	1.8	360	1720	3380	6710
3 < 1.0	—	240	1150	2250	4490
	1.5	640	3110	6100	12000
	1.8	620	2990	5880	11620
	2.0	580	2840	5580	11000
4 < 1.6	—	550	2680	5270	10390
	2.0	800	3880	7620	14990
	3.0	770	3790	7440	14790
	3.5	640	3100	6100	12000
5 < 2.0	—	480	2330	4570	9000
	2.5	960	4800	9840	18000
	3.0	920	4720	9600	17750
	4.0	880	4560	8400	16970
6 < 3.0	—	760	3760	7200	13420
	3.5	1100	5370	10570	20780
	4.0	1070	5200	10230	20120
	5.0	1010	4900	9650	18970
7 < 3.5	—	780	3790	7500	14700
	4.0	1200	6420	11930	23810
	5.0	1150	6200	11700	23200
	6.0	1100	5820	10940	20780
8 < 4.5	—	950	5040	9070	15880
	5.0	1400	6800	13380	26320
	6.0	1360	6580	12950	25500
	7.0	1200	5800	11420	22450
9 < 4.5	—	905	4380	8650	16980
	5.0	1590	7700	15200	29850
	6.0	1570	7600	14950	29400
	8.0	1470	7100	14000	27500
	9.0	960	4650	9200	18000
	—	—	—	—	—
	—	—	—	—	—

## Capacity

Flow rate in m<sup>3</sup>/h Natural gas in standard condition ( $\rho_n = 0,78 \text{ kg/m}^3$ )

KG-factor (Natural gas)		320	1550	3050	6000
Inlet pressure	Outlet pressure	DN 25	DN 50	DN 80	DN 100
Pe (bar)	Pa (bar)				
10 < 4.6	5.0	1760	8650	16400	32990
	6.0	1740	8450	16050	32860
	8.0	1680	8300	15600	31750
12 < 6.0	7.0	1360	6800	12800	25460
	8.0	2070	10050	19800	38900
	10.0	2020	9800	19300	37950
14 < 7.0	10.0	1920	9300	18300	36000
	15.0	1500	7270	14300	28200
	8.0	2400	11600	22850	44900
15 < 7.0	10.0	2350	11400	22420	44100
	12.0	2120	10300	20230	39800
	12.0	1630	7900	15550	30600
16 < 8.0	8.0	2560	12700	23600	48000
	10.0	2400	12400	23200	47620
	12.0	2320	11600	22000	44500
17 < 8.5	14.0	2320	9700	19000	37470
	10.0	1240	6000	11800	23240
	12.0	2710	13150	25900	50900
18 < 9.0	14.0	2600	12600	24800	48750
	14.0	2300	11200	22000	43270
	14.0	1750	8500	16700	32900
20 < 10.0	10.0	2880	14400	28200	54000
	12.0	2840	14100	27500	52600
	14.0	2760	13100	25700	48300
25 < 12.0	15.0	2300	11200	22100	40200
	12.0	2020	9800	19200	33900
	12.0	3040	14700	28950	56900
30 < 15.0	14.0	2850	13700	26950	52900
	16.0	2480	12000	23650	46400
	18.0	1870	9040	17800	34900
35 < 18.0	12.0	3360	16400	32100	
	14.0	3260	15800	31100	
	18.0	3050	14700	28900	
40 < 20.0	1970	1970	9500	18700	
	14.0	4150	20100	39500	
	18.0	4100	19900	39100	
—	20.0	3650	17900	35200	
	18.0	3280	15900	31200	
	18.0	4720	23600	47300	
—	22.0	4530	23400	46000	
	22.0	4340	21100	41400	§
	22.0	5740	27800	54800	§
—	28.0	5530	26800	52700	
	28.0	4560	22100	43400	§
	28.0	6100	30500	57600	§
—	35.0	5970	28900	56800	§
	35.0	4290	20800	40800	§
	—	—	—	—	§
—	—	—	—	§	
—	—	—	—	§	
—	—	—	—	§	

Correction factor for non-natural gas application:

The flow rates are indicated for a 0.6 specific gravity gas.

To determine the volumetric flow rate for gases other than natural gas, the values in the capacity tables should be multiplied or calculated using the sizing equations with a correction factor.

Gas type	Specific Correction gravityfaktor
Air	1.000.77
Butane	2.010.55
Carbon dioxide (dry)	1.520.63
Carbon monoxide (dry)	0.970.79
Natural gas	0.601.00
Nitrogen	0.970.79
Propane	1.530.63
Specific gravity or relative density	

(air = 1, non-dimensional value)

To calculate the correction factor for gases not listed above, the specific gravity (d) of the gas should be taken and used in the following formula:

$$\text{Correction factor } f = \sqrt{\frac{0.6}{d}}$$

## Sizing Equation

For the determination of the device size, the characteristic value KG at the lowest inlet pressure  $p_e$  [bar] and the highest flow in standard state  $q_n$  [m<sup>3</sup>/h] is to calculate.

Supercritical relief:

$$\frac{p_a + 1}{p_e + 1} \leq 0,54 \quad KG = \frac{2 \times q_n}{p_e + 1}$$

Subcritical relief:

$$\frac{p_a + 1}{p_e + 1} \leq 0,54 \quad KG = \frac{q_n}{\sqrt{(p_a + 1)(p_e - p_a)}}$$

Consequently, for natural gas (d = 0.6), the required device size can be read from the lower table.

For other gases, the flow rate is to convert in natural gas before.

Example 1:

$p_{e \text{ min}} = 32 \text{ bar}$   
 $p_{a \text{ max}} = 8 \text{ bar}$

$q_n \text{ max} = 25000 \text{ m}^3/\text{h}$   
Natural gas (f = 1.0)

$$\frac{p_a + 1}{p_e + 1} = 0,27 \quad \text{supercritical}$$

$$KG \text{ requ.} = \frac{2 \times 25000}{33} = \frac{1550}{DN 50 (54/35)}$$

Example 2:

$p_{e \text{ min}} = 12 \text{ bar}$ ,  $q_n \text{ max} = 3600 \text{ m}^3/\text{h}$  nitrogen  
 $p_{a \text{ max}} = 8 \text{ bar} = 4675 \text{ m}^3/\text{h}$  natural gas  
Nitrogen (f = 0,79)

$$\frac{p_a + 1}{p_e + 1} = 0,27 \quad \text{supercritical}$$

$$KG \text{ requ.} = \frac{4675}{\sqrt{8}} = 750 \quad \text{DN 50 (54/15)(8+1) (12)}$$

## Flow Coefficient

Size	Orifice (mm)	Angle	KG-Value
DN 25	31	15°	260
	31	30°	320
	54	15°	850
DN 50	54	35°	1550
	83	15°	1500
	83	35°	3050
DN 80	107	15°	3200
	107	35°	6000

DN 100 \*

\* max inlet pressure 19.3 bar (ANSI 150)

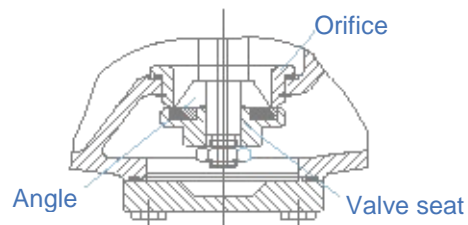

## Safety shutoff valve SL-IZN.1, SL-IZM.1 and SL-IZH.1

max. Inlet pressure 40 bar

Adjusting range / Function pso (protecting against overpressure)

Type	Spring range wao	Spring-No.	Colour	Wire Ø [mm]
Low pressure measuring unit N.1	35 - 250 mbar	955-202-36	red	1.8
	200 - 800 mbar	955-202-37	green	2.5
Medium pressure measuring unit M.1	0.6 - 6.6 bar	955-202-38	yellow	3.6
High pressure measuring unit H.1	3.5 - 10.5 bar	955-201-68	black	6
	10.5 - 21 bar	955-201-69	grey	7
	18.0 - 40 bar	955-202-84	yellow	10

Minimal difference pressure ( $\Delta P_w$ ) between pas regulator and pso SSV

- 20 mbar

SL-IZN.1 Accuracy group (AG):

pso:

- 0.035 - 0.10 bar: AG 10
- >0.10 - 0.80 bar: AG 5

SL-IZH.1 Accuracy group (AG):

pso:

- 3.5 - 10.5 bar: AG 2.5
- 10.5 - 40.0 bar: AG 1

SL-IZM.1 Accuracy group (AG):

pso:

- 0.6 - 6.6 bar: AG 5

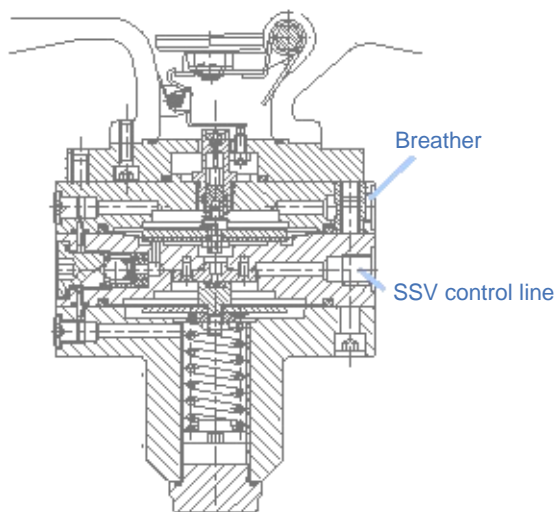

Fig 2: Safety shutoff valve Type SL-IZ - sectional view

## Safety shutoff valve Type 022

Max. Inlet pressure 16 bar

Adjusting range / Function Pso and Psu (protecting against over- and-underpressure)

Function	Spring Range		Spring Code	Colour	Wire Ø [mm]
	wao	wau			
Overpressure (pso)	20 - 60 mbar		955-200-22	red	1.4
	50 - 120 mbar		955-200-23	blue	1.6
	100 - 450 mbar		955-200-24	green	2.6
	0.35 - 1.0 bar		955-203-41	black	3.2
	0.8 - 1.7 bar		955-203-42	yellow	4.0
Underpressure (psu)		10 - 50 mbar	955-200-32	red	0.8
		40 - 120 mbar	955-203-51	brown	1.25
		100 - 220 mbar	955-203-52	yellow	1.6

SAV 022 Accuracy group (AG):

pso:

- 40 - 400 mbar:•
- > 0.4 - 1.0 bar:
- > 1.0 - 1.7 bar

- AG 10
- AG 5
- AG 2.5

psu:

- 10 - 20 mbar:
- >20 - 220 mbar:

- AG 30
- AG 15

Minimal difference pressure ( $\Delta P_w$ ) between pas regulator and Pso/Psu SSV

- 10 mbar for Psu and
- 20 mbar for Pso

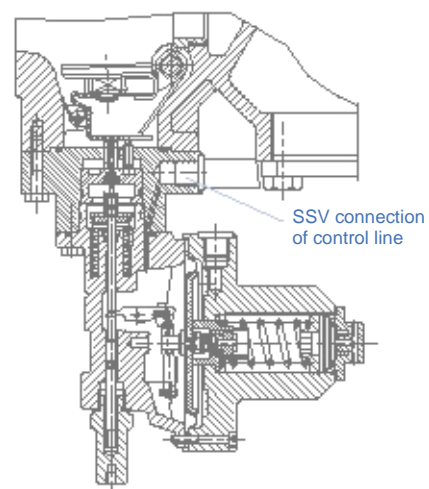

Fig 4: Safety shutoff valve 022 - sectional view



## Safety shutoff valve SID / RSL

max. Inlet pressure 40 bar

Adjusting range / Function pso and psu (protecting against over- and underpressure)

Function Pso & Psu	Spring Range			Spring Code	Colour	Wire Ø [mm]
	wao	wau				
Low Pressure- measuring unit N*)	5	- 110	mbar	955-201-65	black	3.2
	80	- 220	mbar	955-201-66	green	4.0
Medium Pressure measuring unit M	100	- 250	mbar	955-201-65	black	3.2
	200	- 470	mbar	955-201-66	green	4.0
	0.45	- 1.5	bar	955-201-67	brown	5.6
	1.0	- 2.5	bar	955-201-68	black	6.0
	2.0	- 4.0	bar	955-201-69	grey	7.0
High Pressure measuring unit H	3.0	- 6.6	bar	955-201-70	red	8.5
	5 - 12 bar	- 1 - 12	bar	955-201-69	grey	7.0
	11- 22 bar	- 11 - 20.	bar	955-203-64	green	8.0
RSL-High Pressure measuring unit H	18 - 40 bar			955-202-84	yellow	10.0
		1 - 20	bar	955-201-70	red	8.5

\* with protection of SRV 285 D max., inlet pressure = 40 bar

Minimal difference pressure ( $\Delta P_w$ ) between pas regulator and Pso/Psu SSV

- 10 mbar for Psu and
- 20 mbar for Pso

SID-N Accuracy group (AG):

pso:

- 20 - 40 mbar: AG 10
- > 40 - 220 mbar: AG 5

psu:

- 5 - 20 mbar: AG 30
- > 20-220 mbar: AG 15

SID-M Accuracy group (AG):

pso:

- 0,1 - 0,45 bar: AG10
- > 0,45 - 1,0 bar: AG 5
- > 1,0 - 6,6 bar: AG 1

psu:

- 0,1 - 0,45 bar: AG 15
- > 0,45 - 6,6 bar: AG 5

SID-H Accuracy group (AG):

pso:

- 5,0 - 6,0 bar: AG 5
- > 6,0 - 22,0 bar: AG 1

psu:

- 1,0 - 20,0 bar: AG 5

RSL-H Accuracy group(AG):

pso:

- 18,0 - 30,0 bar: AG 2,5
- > 30,0 - 40,0 bar: AG 1

psu:

- 1,0 - 20,0 bar: AG 5

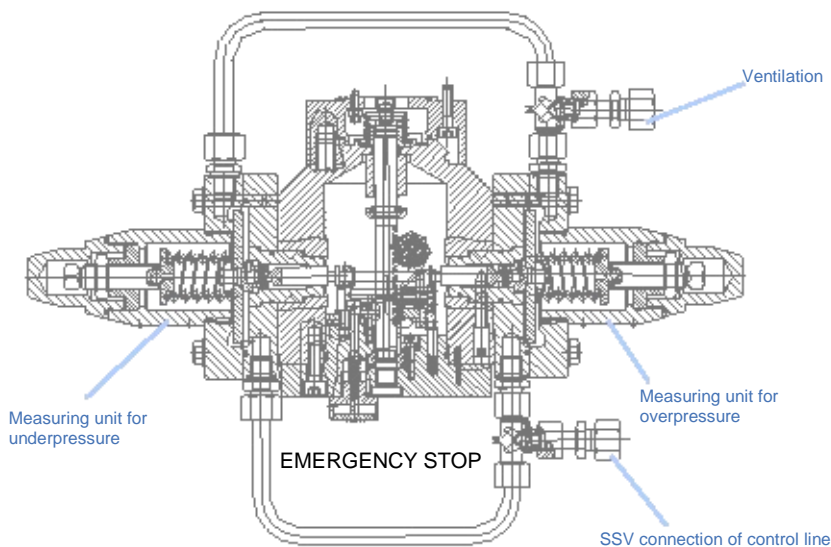

Fig 5: Safety shutoff valve type SID-MM - sectional view

## Dimensions (in mm)

### Regulator

DN	L	A	B	C	D		E	E	E	X
					without SSV	with SSV				
25	180	260	500	400	90	55	280	250	230	105
50	250	360	500	430	125	88	330	300	280	110
80	300	360	500	450	150	100	330	300	280	110
100	350	360	500	500	450	175	175	330	280	120

### Safety Shutoff valve (SSV)

DN	F	F	F	F	G	H	H	H	H	I	J
	SL-IZ	SL-IZ	SID	SID		SL-IZ	SID	SID	SID		
	N, M	H	N	M, H		N, M, H	N	M	H		
25	240	280	290	280	105	Ø140	Ø200	Ø130	100	140	132
50	245	285	290	280	108	Ø140	Ø200	Ø130	100	200	135
80	285	330	335	325	151	Ø140	Ø200	Ø130	100	210	178

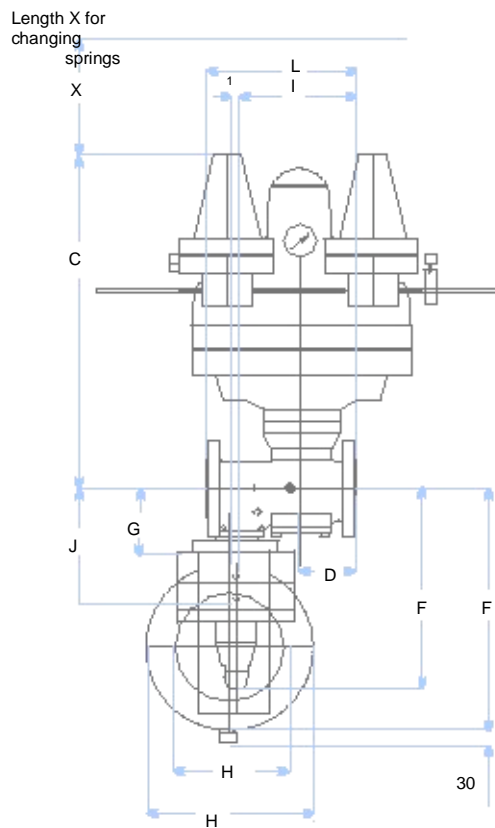
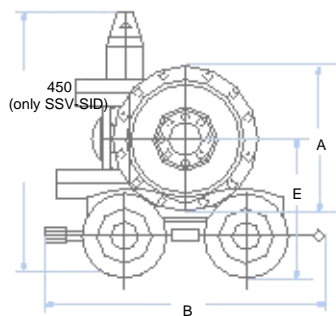

Fig 6: Gas pressure regulator 12 P MM with SSV - Dimension

## Weight / Connection parts

Diaphragm-housing		Orifice Ø (mm)	Number of holes	Connection (Flange)			Weight (kg) regulator		
DN	Ø			Thread	6 kt Bolt DIN 933-5.8	Hex.- screw DIN 2510	without SAV	with SAV SL	with SAV SID
25	8"	31	4	M 12	M 12x40	-	33	37	42
50	12"	54	4	M 16	M 16x45	-	42	46	51
80	12"	83	8	-	-	M 16x70	65	71	76
100	12"	107	8	-	M 16x70 (PN 16)	-	82	-	-

## Thread pulse connection

	Main valve	SVV	Needle valve	Feeder RV-	Pilot RP-
Inlet pressure	-	-	-	G 1/4 EO 10	-
Intermediate pressure	-	-	-	G 1/4 EO 10	G 1/4 EO 10
Actuating pressure	G 1/4 EO 10	-	G 1/4 EO 10	-	G 1/4 EO 10
Outlet pressure	1/2 NPT EO 12	G 1/4 EO 12	-	-	G 1/4 EO 12
Ventilation RV/RP	-	-	-	G 1/4 EO 12	G 1/4 EO 12
Ventilation SSV		G 1/4 EO 12			
Blow-off/Ventilation		G 1/4 EO 12			

The connection for pulse / ventilation are marked with coloured plastic-sticker.  
The flow direction is marked with an arrow on the body.

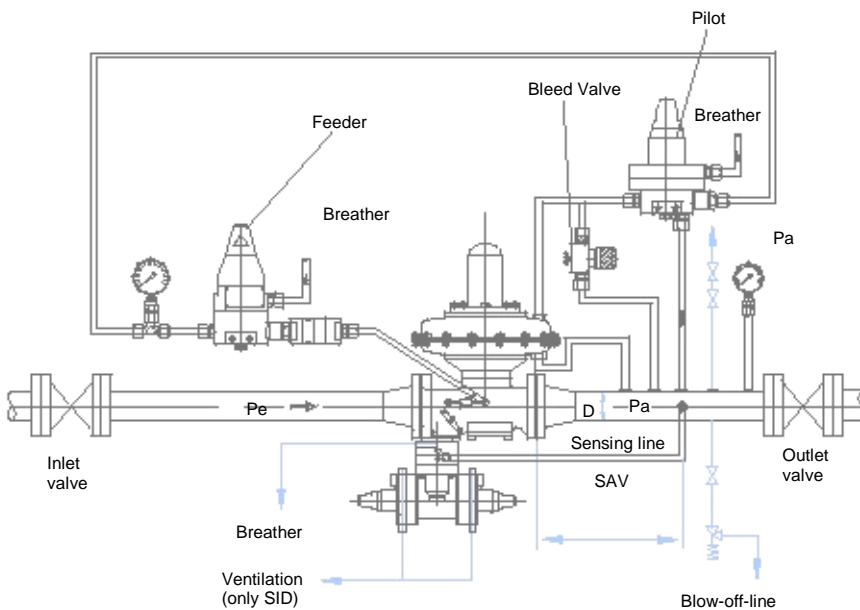

## Type Designation

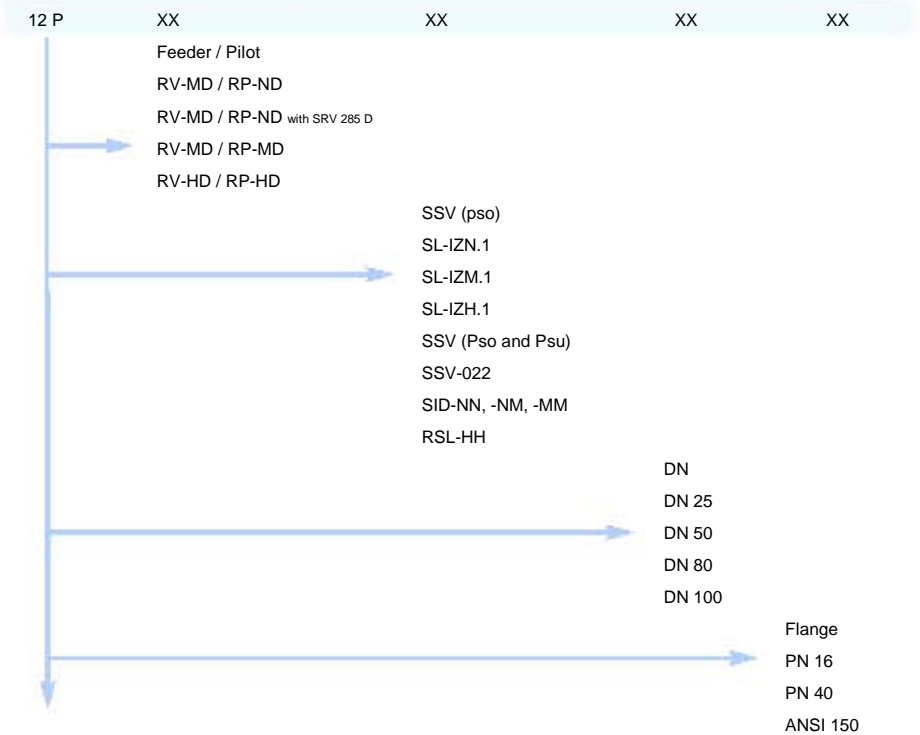

Device designation example: 12 P-MM-SL-IZM.1-DN 50 PN 16

## Option

Silencer (reducing of noise up to 10 dB(A))  
 Optical flow indicator  
 SSV position indicator  
 SSV with manual release  
 SSV with electrical release by solenoid valve

## Information to be specified when ordering:

- Regulator type code
- SSV type
- Minimum and maximum inlet pressures
- Outlet pressure range setting
- Outlet pressure setting
- OPSO setting\*
- UPSO setting\*
- Connection type
- Options

\* If requested